



88A-200 Series

Carbon Steel ANSI Class 150 Flanged Full Port Ball Valve - 1/2" through 1"

STANDARDS COMPLIANCE

Refer to page D-A

MATERIALS OF CONSTRUCTION

Description (1/2" & 3/4" Valves)	Material
1. Body	ASTM A216 WCB
2. Retainer	ASTM A108 Type 1215
3. Ball	ASTM A108 Type 1215
4. Stem	ASTM A108 Type 1215
5. Packing Gland	ASTM A108 Type 1215
6. Stem Seals	PTFE
7. Seats	RPTFE
8. Stem Nut	300 Series Stainless Steel
9. Lever	300 Series Stainless Steel w/Vinyl Grip
10. Stem Bearing	RPTFE
11. Stop	300 Series Stainless Steel
12. Body Seal	RPTFE
13. Lock Washer	300 Series Stainless Steel
14. Grounding Spring	ASTM A313 Stainless Steel
15. Grounding Spring	ASTM A313 Stainless Steel

Description (1" Valves)	Material
1. Body	ASTM A216 WCB
2. Retainer	ASTM A108 Type 1215
3. Ball	ASTM A108 Type 1215 Chrome Plated
4. Stem	ASTM A108 Type 1215
5. Packing Gland	ASTM A108 Type 1215
6. Stem Seals	PTFE
7. Seats	RPTFE
8. Gland Screws	ASTM A193 B7
9. Gland Plate	302 or 304 SS
10. Stem Nut	316 SS
11. Lever	ASTM A366 Steel with Vinyl Grip
12. Stem Bearing	RPTFE
13. Stop	ASTM A108 Type 1215
14. Stop Screw	SAE J429 Grade 2
15. Lock Plate	ASTM A366 Steel
16. Body Seal	RPTFE
17. Lockwasher	302 or 304 SS
18. Grounding Spring	SS

STANDARD FEATURES

Refer to page D-A

VARIATIONS AVAILABLE:

88A-240 Series (316 SS Ball & Stem)

88A-230 Series (Ni-Cu Ball & Stem)

OPTIONS AVAILABLE:

(SUFFIX)	OPTION
-01-	Standard
-10-	SS Lever and Nut
-14-	Side Vented Ball (Uni-Directional)
-15-	Wheel Handle, Steel
-21-	UHMWPE Seats
-24-	Fire Safe (Graphite Packing and Seal)
-35-	PTFE Seats and Seals
-38-	PEEK Seats and Graphite Packing
-49-	Assembled Dry
-60-	Grounded Ball and Stem
-65-	MPTFE Seats and Graphite Packing
-67-	Cleaned For Industrial Gases
-69-	Drilled and Tapped Purge Port with Plug
-70-	4" Extended Bonnet
-73-	316 SS Spiral Wound Gaskets w/PTFE Filler
-74-	316 SS Spiral Wound Gaskets w/Graphite Filler
-76-	Live Loaded 87A/88A Series (Lever)
-80-	Multi-Seal (Super TFE) 87A/88A Series

For Pressure/Temperature Ratings, Refer to Page M-7, Graph No. 1

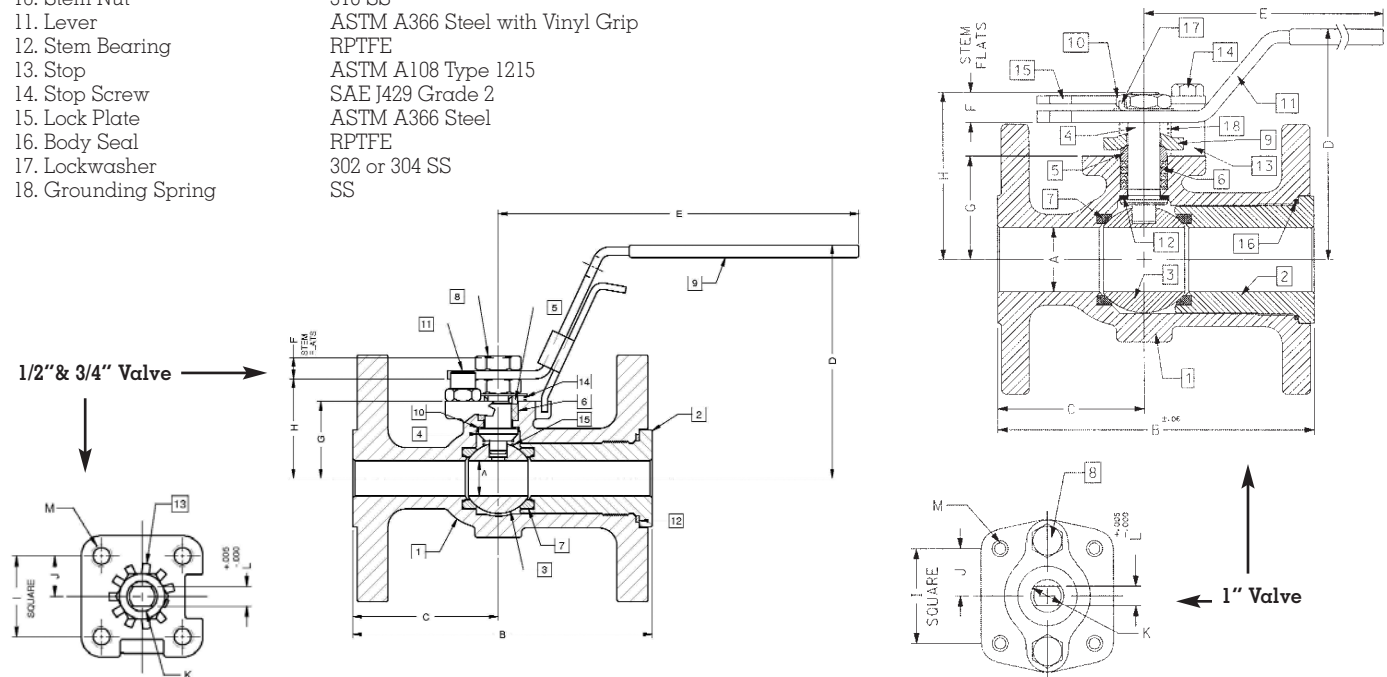

NUMBER	SIZE	A	B	C	D	E	F	G	H	I	J	K	L	M	WT.
88A-203-01	1/2"	0.50	4.25	2.06	3.31	5.11	.30	1.09	1.41	1.002	.501	.375	.245	10-24	5.0
88A-204-01	3/4"	0.75	4.62	2.18	3.89	5.53	.36	1.65	1.99	1.392	.696	.500	.287	1/4-20	6.0
88A-205-01	1"	1.00	5.00	2.32	4.62	6.53	0.47	1.62	2.15	1.392	0.696	0.500	0.287	1/4-20	7.0